

Primary Lithium Battery

CR14250SC

3.0V [Li-MnO₂]

1/2AA-size bobbin cell



BENEFITS

- High Voltage Response, Stable During Most of the Lifetime of the Application
- Energy Density up to 830Wh/L
- Wide Operating Temperature Range (-40°C ~+85°C)
- Low Self-discharge Rate (less than 1% per year after 1 year of storage at +25°C)

KEY FEATURES

- Optimized Battery Structure, Full Discharge Capacity
- Long Endurance
- No Passivation
- GB 8897.4-2008, IEC 60086.4:2014 and RoHS

MAIN APPLICATIONS

- Security System
- Smart Metering
- RFID and Tracking System
- Wireless Transmitting
- Smart Home Devices
- Military Devices

Reference Data

Electrical characteristics

Open circuit voltage (at 25°C)	≥3.10V
Nominal capacity	1050mAh
(At +25°C, battery discharged at continuous current 1mA until voltage reaches cut-off voltage 2.0V. The capacity can vary at different temperature, discharge current or cut-off voltage.)	
Maximum continuous current	15mA
(At +25°C, 2.0V cut-off, battery discharged for minimum 50% of rated capacity.)	
Maximum pulse discharge current	100mA
(Maximum pulse discharge current is 100mA. Discharge capacity of the battery will change with the pulse characteristics and ambient temperature as well as storage situation. For more detail, please inquiry HCB.)	
Storage (recommended)	≤+30°C
(For more severe conditions, consult HCB)	
	≤75%RH
Operating temperature range	-40°C~+85°C
(Consult HCB when using batteries at temperatures exceeding -20°C~+60°C.)	

* The data in this document are for descriptive purposes only and are not intended to imply any guarantee or warranty.

HCB BATTERY CO., LTD

Add: Special No 1. Taizhong Avenue, Gaoqiao Industrial Park, Wujiashan Economic Development Zone, Wuhan, P.R.China

P.O.: 430040
Tel: +86(0)27 83248452
Fax: +86(0)27 83248455

Email: haocheng@cnhcb.com
Web: www.cnhcb.com
No.: HCB-MKT.PM-S[V2.0 2018 02]

Primary Lithium Battery CR14250SC



3.0V [Li-MnO₂]

1/2AA-size bobbin cell

Physical characteristics

Diameter (max)	14.5mm
Height (max)	25.5mm
Typical weight	10.00g
Li metal content	0.30g

MSDS as per request
Diode (1N4007, 1N5819)
PTC (SRS175...)

Tag, wire, connector, etc. available

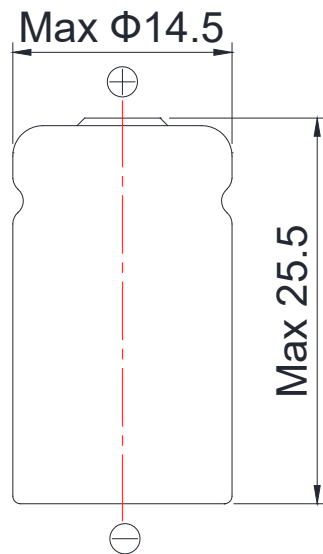

Dimensions in mm (GB1804-m)

WARNING:

- Do Not Short Circuit
- Do Not Recharge
- Do Not Puncture
- Do Not Crush
- Do Not Dismantle
- Do Not Incinerate
- Do Not Mix New and Used Batteries
- Do Not Heat Above 100°C

1. Typical discharge profiles at 25°C
(at mid-discharge)

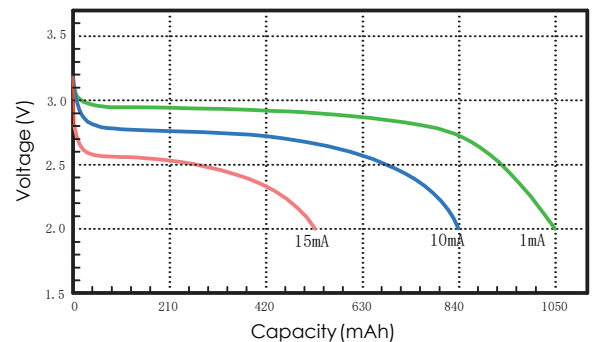

2. Typical discharge profiles with different temperature
(at discharge stable phase)

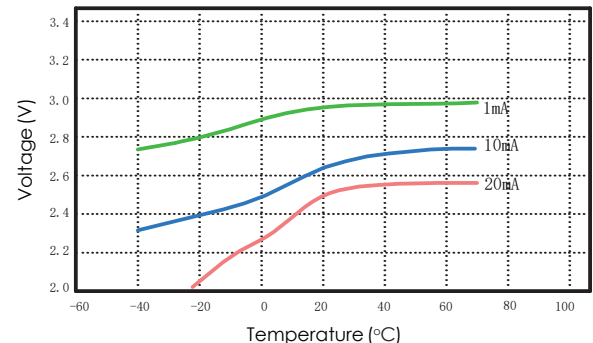

3. Storage characteristics

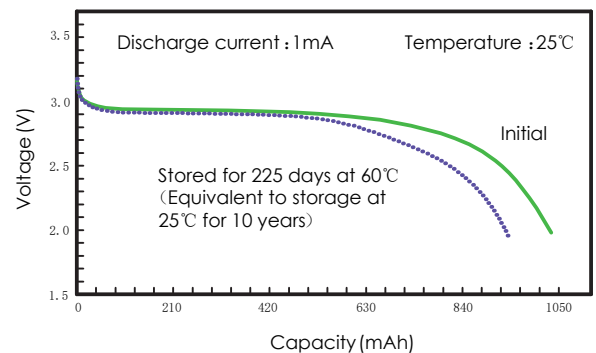

HCB BATTERY CO., LTD

Add: Special No 1. Taizhong Avenue, Gaoqiao Industrial Park,
Wujiashan Economic Development Zone, Wuhan, P.R.China

P.O.: 430040
Tel: +86(0)27 83248452
Fax: +86(0)27 83248455

Email: haocheng@cnhcb.com
Web: www.cnhcb.com
No.: HCB-MKT.PM-S[V2.0 2018 02]